

Poka-Yoke Probe

Compact part-presence sensor

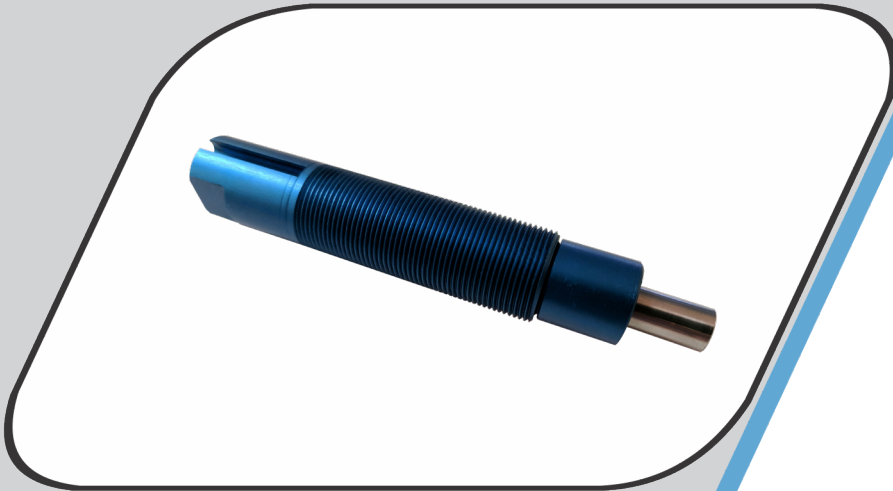

Features

- High Strength 7075-T6 Aluminum
- M18 threaded body
- 10mm Stroke
- Stainless Steel Spring
- Rare Earth Magnet

PYPA-10T12

Spring Rate 12 lbf/in with
Approx 6 lbf at full compression

PYPA-10T06

Spring Rate 6 lbf/in with
Approx 3 lbf at full
compression

Switch Options*

- Standard Round Solid State Switch

Probe Options*

- Up to 50mm Long
- PEEK or Ceramic Tips

*Sold separately



Shown with cylinder switch and 50mm probe

5825 Triangle Dr, Suite 101
Raleigh, NC 27617
833-2-CAROMATION
(833-222-7662) Toll free
www.caromation.com

Applications

- Weld Nut Check *Shown >>*
- Small Part Switch
- Wash Down Applications

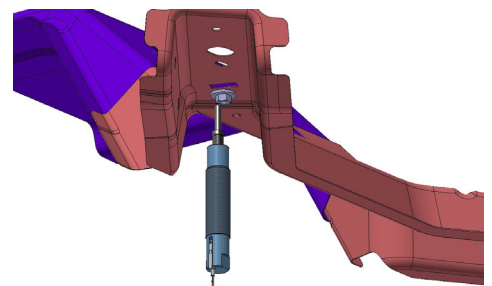

CAROMATION
simplifying automation

POKA-YOKE PROBE

ORDER INFORMATION

POKA YOKE PROBE BASE UNIT				SPRING RATE	SWITCH CODE	PROBE										
P	Y	P	A	-	1	0	T	0	6	-	B	A	-	C	2	5

SPRING RATE		
0	6	6 LBF/IN SPRING; APPROX 3 LBF RETRACTED
1	2	12 LBF/IN SPRING; APPROX 6 LBF RETRACTED

SWITCH CODE - SEE SWITCH CHART		
0	0	NO SWITCH
S	A	SMC SWITCH
B	A	BALLUFF SWITCH
T	A	TURCK SWITCH

PROBE CONFIGURATIONS			
0	0	0	NO PROBE
C	2	5	CERAMIC TIP, 25mm LONG
C	5	0	CERAMIC TIP, 50mm LONG
P	2	5	PEEK TIP, 25mm LONG
P	5	0	PEEK TIP, 50mm LONG

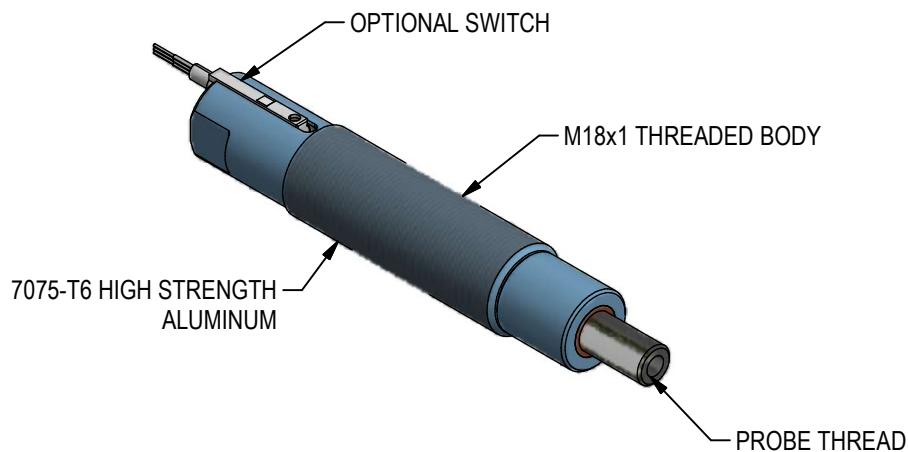

POKA-YOKE PROBE

GENERAL INFORMATION

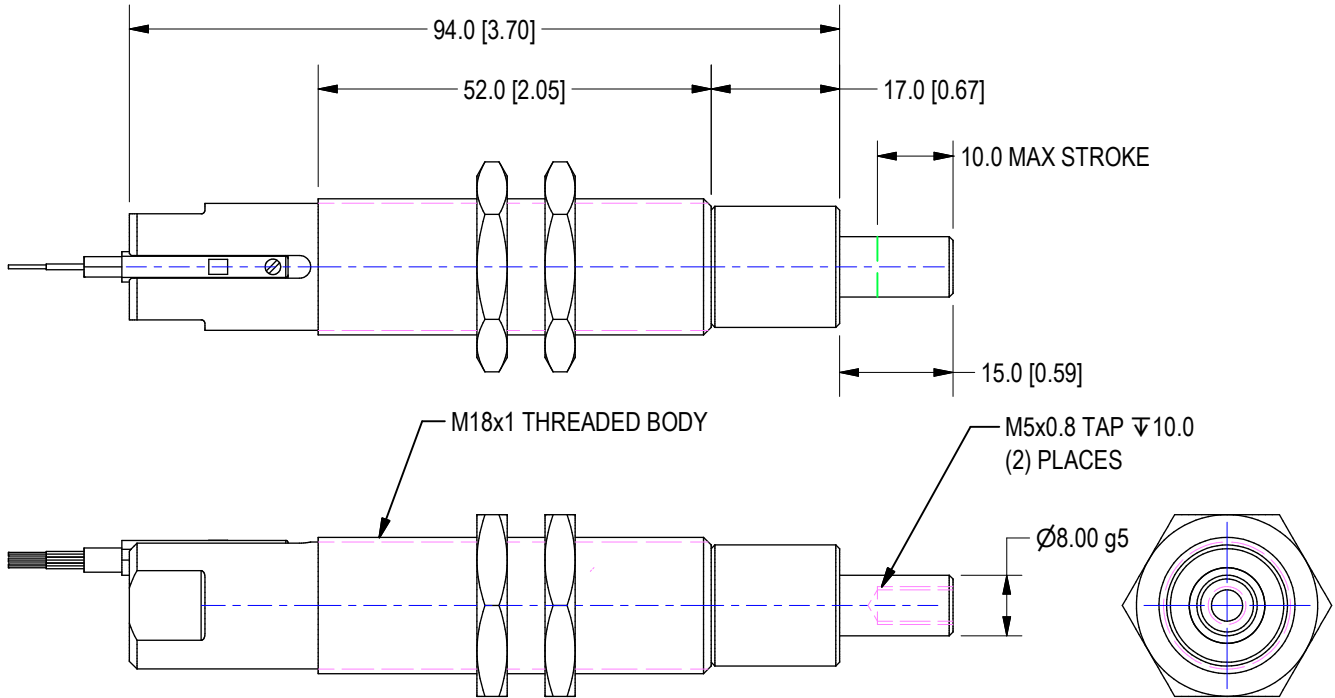

INTERCHANGEABLE MOUNTING WITH STANDARD 18mm BARREL PROX SWITCHES

MOUNTING EXAMPLES

- M18x1 THREADED HOLE USING 1 NUT (PROVIDED)
- 19mm DRILL THROUGH HOLE USING 2 NUTS (PROVIDED)
- INDUSTRY STANDARD SWITCH MOUNTING BRACKETS (NOT SUPPLIED)

SWITCH INFORMATION

Compatible Solid State Switches		
Normally Open, 3 Wire, PNP, 24V, M12 Connector with 4 Pins, 0.5m		
Vendor	Caromation Code	Vendor Part Number
SMC	SA	D-M9PSDPC
Balluff	BA	BMF00ER
Turck	TA	BIM-UNR-AP6X-0.5M-RS 4T W/M

APPROX 0.08kg (.20 lbf)

CAROMATION

simplifying automation

POKA-YOKE PROBE

PROBE INFORMATION

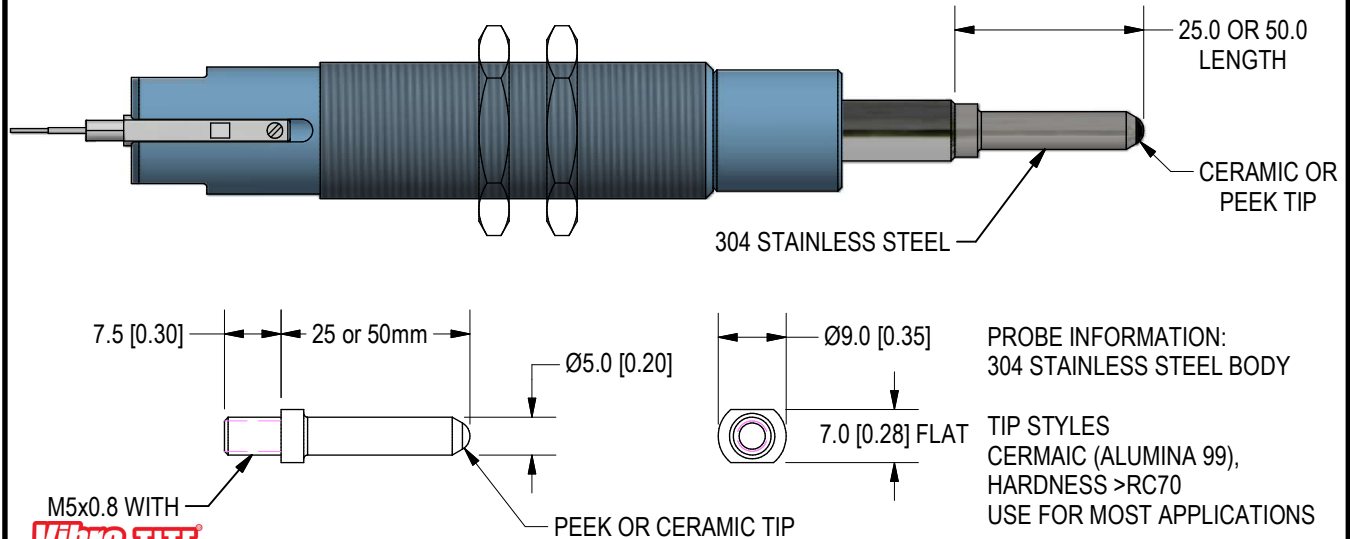

PROBE INFORMATION:
304 STAINLESS STEEL BODY

TIP STYLES
CERMAIC (ALUMINA 99),
HARDNESS >RC70
USE FOR MOST APPLICATIONS

PEEK TIP
HARD PLASTIC USED FOR
NON-MARRING APPLICATIONS

CAROMATION PROUDLY USES **Vibra-TITE** THREADMATE.

INTERNAL COMPONENTS, ALONG WITH THE OPTIONAL PROBE, ARE FACTORY SUPPLIED WITH AN ADJUSTABLE, REMOVABLE, AND REUSABLE THREAD LOCKER THAT MEETS US MILITARY, DOD, AND AEROSPACE STANDARDS. NO NEED TO WORRY THAT THE SCREWS WILL VIBRATE LOOSE. IF ANTI-TAMPERING IS REQUIRED, PLEASE CONTACT CAROMATION.

THE M18x1.0 THREADED BODY DOES NOT HAVE THREADMATE PRE-APPLIED.

SPARE PARTS INFORMATION

TO ORDER AS SPARE PARTS OR NOT AS AN ASSEMBLY

PROBE INFORMATION

PYPP-{MATERIAL C OR P}LENGTH

PYPP-C25 FOR A 25mm LONG CERAMIC TIP PROBE

SPRING INFORMATION

PPYS-06 FOR 6 LBF/IN SPRING

PPYS-12 FOR 12 LBF/IN SPRING